

# SKF Microlog Analyzer dBX Accessories



# Foreword

Unmatched versatility, reliability and functionality have made the SKF Microlog Analyzer dBX series of data collectors the premier choice for portable, condition monitoring instruments.

Designed to help users establish or upgrade an existing condition monitoring program, SKF Microlog dBX handle the tasks required to perform predictive maintenance on rotating machinery in countless industries.

## Data capture from a range of sources

SKF Microlog dBX automatically collect both dynamic (vibration) and static (process) measurements from almost any source, including handheld and magnetically mounted accelerometers, permanently mounted vibration sensors or on-line monitoring systems.

## State-of-the-art operating technology

With robust, high-speed data processors and optimum data storage capacity, SKF Microlog dBX are equipped to operate within today's most advanced computerized maintenance management systems. Instruments can be purchased with a range of individual modules and accessories for specific types of analysis required to meet your monitoring needs.



# Contents

## SKF Microlog Analyzer dBX

CMVA 90 .....	4
---------------	---

## Accelerometers

General purpose, low profile, side exit industrial accelerometer, CMSS 2200 and CMSS 2200-M8 .....	6
General purpose, top exit industrial accelerometer, CMSS 2100 ..	8
Small footprint accelerometer with integral cable, CMSS 2111 ..	10
General purpose sensor kit, CMSS 1500-K .....	11
Medium duty magnetic base, CMSS 908-MD .....	12
Quick connect/disconnect sensor mounting pads, CMSS 9100DB1, CMSS 9100DP1, CMSS 9100DP2 .....	13

## Cables

Cable recommendations .....	14
-----------------------------	----

### Accelerometer cables

Splitter, straight cable, CMAC 5079 .....	15
Accelerometer coiled cable, 45 cm (1.5 ft.), CMAC 9020 .....	15
Accelerometer coiled cable, 2 m (6.56 ft.), CMAC 5209 .....	16

### Tachometer cables

BNC tachometer straight cable, CMAC 5211 .....	16
Laser tachometer kit straight cable, 2 m (6.56 ft.), CMAC 5214 .....	17

### Extension cables

CH1 signal input straight extension cable, 5 m (16.4 ft.), CMAC 5036 .....	17
CH1 signal input straight extension cable, 10 m (32.8 ft.), CMAC 5037 .....	18
Tachometer straight extension cable, 10 m (32.8 ft.), CMAC 5044 .....	18

### Miscellaneous cables

Cable converter, two pin MIL to BNC, CMAC 3715 .....	19
Signal input straight cable, CMAC 5023 .....	19
Power/Trigger splitter straight cable, CMAC 5032 .....	20
Signal input straight cable (BNC connector), CMAC 5088 ..	20
Signal input coiled cable (BNC connector), CMAC 5093 .....	21
Accelerometer coiled BNC cable, CMAC 9100 .....	21
Accelerometer (M12) coiled BNC cable, CMAC 9110 .....	21

## Hardware

Laser tachometer kit, CMAC 5030K .....	22
Modal analysis hammer kit, CMAC 5056 .....	23
Modal analysis hammer kit, CMAC 5059 .....	26

## Accessories

Battery (CMVA 90), CMAC 9005 .....	28
Universal power supply, CMAC 9001 .....	29
Power supply adapter cable, CMAC 9002 .....	29
Neck strap, CMAC 9017 .....	30
Hand strap, CMXA 9016 .....	30
USB communications cable, CMAC 9010 .....	31

### ⚠ WARNING

Unless otherwise stated in the specifications, the products in this catalog are not certified for use in hazardous areas with explosion risk.

# SKF Microlog Analyzer dBX

## CMVA 90

### Advanced data collector / FFT analyzer

The SKF Microlog dBX is the most advanced large screen vibration analyzer offered by SKF today. Its features allow you to capture a wide range of vibration data quickly. The analyzer provides the flexibility to support applications that are most important to your company's specific predictive maintenance program. Developed for use in a wide range of industries.

### Key features

- **Large screen** – 10.1 in. high resolution colour display for easy viewing and analysis in any light. Displays up to 6 plots on screen
- **Simultaneous triaxial measurements** for fast data collection
- **MPA-in-a-flash** – SKF's fastest vibration analysis, saves time taking measurements
- **Easy to use** – get you started quickly with minimum training
- **Rugged** – dust and water ingress IP 65 design for reliability in industrial environments
- **Rechargeable lithium battery** supports up to eight hours of continuous data collection

### Modular offers

The modular application design of the SKF Microlog dBX offers customers the option to upgrade and expand functionality without having to buy another instrument. Sensors and cable accessories are inter-changeable between previous SKF Microlog CMXA series models. To add additional functionality, units can be upgraded to more advanced models, by simply purchasing optional accessories.



*SKF Microlog dBX puts the power of knowledge engineering in your hands with advanced vibration monitoring technologies that have made the SKF Microlog dBX series of analyzers the premier choice for portable condition monitoring. Designed to handle a wide range of tasks required for analysis of rotating machinery in countless industries.*



*SKF Microlog dBX is a full-featured, four channel, high performance portable, route data collector/FFT analyzer.*

### Specifications

#### Measurements

- Input channels: 4 analogue input channels with IEPE bias voltage, tacho channel with built-in power supply for laser tachometer
- Data acquisition: 24-bit A/D converter (>90 dB dynamic range)
- Max. bandwidth: 40 kHz (102.4 kHz sampling rate)
- Accuracy: +/- 2.5% of full scales range
- Measurements parameters: acceleration, velocity, displacement, SKF gE bearing condition, phase, voltage, and speed

#### Environmental

- Operating temperature: -10 to +50 °C (13 to +122 °F)
- Storage temperature: -20 to +60 °C (-4 to +140 °F)
- IP rating: IP65 dust and water ingress to EN 60529 specification
- Rugged: 1.2 m (4 ft.) drop test to MIL STD 810 specification
- Approvals: CE, UKCA, FCC, KC, RCM

#### Physical

- Dimensions: 300 × 195 × 50 mm (11.8 × 7.7 × 1.97 in)
- Weight: 1.9 kg (4.2 lbs), 1.7 kg using single battery
- Keypad: Backlit keys, up, down, right and left, OK, Cancel, Menu key, Right click, Cursor toggling, Zoom, Start/Stop measurement key, Power On/Off
- LCD screen: 10.1 in. multi-point colour touch screen, 1280 × 800 pixels, for indoor and outdoor use
- Camera: built-in, rear facing camera
- RF tag identification: near-field communication (NFC) reader, built-in, located on rear
- PC interface: USB A-type connector

#### Power source

- Power: 2 × lithium-ion polymer rechargeable/swappable batteries
- Battery life up to 8 hours of data collection use

Module	Application	CMVA 90 M	CMVA 90 F
	SKF Data Collector is used as part of a condition-based maintenance program. It enables users to collect a sequence of pre-defined measurements along a 'route' through a plant area. Routes are downloaded on to the SKF Microlog dBX from SKF host software.	●	●
	SKF Microlog dBX Analyzer allows you to set-up user-defined measurements and immediately collect data for analysis purposes, at locations not downloaded as part of a route.	●	●
	SKF Balancing is an easy-to-follow procedure to perform precision balancing in 1,2,3,4 planes, and overhung rotor applications. Features include a heavy-spot locator, multiple points on clear display screens and graphical representations.	●	●
	SKF Bump Test is a simple and easy tool for performing an impact test, in order to identify natural frequencies of a machine or structure.	●	●
	SKF gE Enveloping is an analysis tool, using field-proven SKF algorithms, to detect rolling element bearing defects at an early stage.	●	●
	SKF FRF & ODS Analysis acquires Frequency Response Function data that can be used to determine the Operating Deflection Shape (ODS) of a machine. The data is uploaded into a host software to visualize the behavior on a wire-frame model.	●	●
	SKF Order Tracking enables experienced users to diagnose complex rotating machinery issues by means of order analysis, with the SKF Microlog dBX connected to a speed and/or phase reference signal.		●
	SKF Data Recorder enables you to record vibration signal waveforms of user-defined lengths in time. Recorded waveforms can be imported into SKF host software for post-processing, where they are typically used to analyse low-speed machinery.		●
	SKF Orbit Analysis provides shaft orbit displays, for diagnosis of issues in fluid-film bearings. The SKF Microlog dBX would typically be connected to buffered signal outputs, X-Y and phase reference, of an installed machinery protection system.		●
	SKF RunUp CoastDown is used to identify excitation of critical resonant frequencies during the start-up or shut-down phase of a machine. It is normally applied to larger variable-speed equipment and SKF Microlog dBX would typically be connected to buffered signal outputs, X-Y and phase reference, of an installed machinery protection system.		●

#### Ordering information

##### CMVA 90 M-CK-SL kit includes

- CMVA 90-M Microlog dBX, programmed with SKF Data Collector, SKF dBX Analyzer, SKF Balancing, SKF gE Enveloping, SKF Bump Test and FRF & ODS Analysis applications
- CMAC 9001 Universal power supply with 4 power cords
- CMAC 9002 Power adapter cable
- CMAC 9005 Two (2) batteries
- CMAC 9010 USB A-Type to A-Type communications cable
- CMAC 9015 SKF branded carry case
- CMAC 9016 Two (2) hand straps
- CMAC 9017 Neck strap
- CMSS 2200 Industrial accelerometer, side exit
- CMAC 5209 Accelerometer coiled cable, 2 m (6.56 ft.)
- CMSS 908-MD Medium duty magnetic base
- Certificate of calibration and conformance

##### CMVA 90 M-F-UPGRADE license includes

- Upgrade from standard to extended version, license for SKF Order Tracking, SKF Data Recorder, SKF RunUp CoastDown and SKF Orbit Analysis

##### CMVA 90 F-CK-SL kit includes

- CMVA 90-F Microlog dBX, programmed with SKF Data Collector, SKF dBX Analyzer, SKF Balancing, SKF gE Enveloping, SKF Bump Test, SKF FRF & ODS Analysis, SKF Order Tracking, SKF Data Recorder, SKF RunUp CoastDown and SKF Orbit Analysis applications
- CMAC 9001 Universal power supply with 4 power cords
- CMAC 9002 Power adapter cable
- CMAC 9005 Two (2) batteries
- CMAC 9010 USB A-Type to A-Type communications cable
- CMAC 9015 SKF branded carry case
- CMAC 9016 Two (2) hand straps
- CMAC 9017 Neck strap
- CMSS 2200 Industrial accelerometer, side exit
- CMAC 5209 Accelerometer coiled cable, 2 m (6.56 ft.)
- CMSS 908-MD Medium duty magnetic base
- Certificate of calibration and conformance

#### Optional accessories for CMVA 90

A number of accessories are available to complement the SKF Microlog dBX. For technical details or information on any item, specifications and photographs are available later in the catalog.

# Accelerometers

## CMSS 2200

### Industrial accelerometer, side exit

The CMSS 2200 accelerometer is a good multi-purpose sensor. The sensor is commonly deployed in the following industries:

- Power Generation (Fossil, Nuclear, Hydro, Wind)
- Pulp and Paper
- Mineral Processing
- Food and Beverage
- Automation
- Metals
- Water and Waste Water

### Features

- For use with SKF portable data collection instruments
- Rugged, economical and all around general purpose sensor
- 100 mV/g sensitivity to optimize use in multiple applications
- Exceptional bias voltage (BV) stability at elevated temperatures
- Designed for exceptional low noise level over a wide temperature range
- Meets CE, EMC requirements
- Captive mounting bolts (1/4–28 and M6 × 1.00) provided
- Corrosion resistant and hermetically sealed for installation in high humidity areas
- Reverse polarity wiring protection

### Recommended connector/cable assembly

- CMAC 5029 and CMAC 9100

### Specifications

Specifications conform to ISA-RP-37.2 (1-64) and are typical values referenced at 24 °C (75 °F), 24 V DC supply, 4 mA constant current and 100 Hz.

### Dynamic

- Sensitivity: 100 mV/g
- Sensitivity precision: ±5% at 24 °C (75 °F)
- Acceleration range: 80 g peak
- Amplitude linearity: 1%
- Frequency range:
  - ±10%: 1.0 to 5 000 Hz
  - ±3 dB: 0.7 to 10 000 Hz
- Resonance frequency, mounted, nominal: 22 kHz
- Transverse sensitivity: ≤ 5% of axial
- Temperature response: See graph



### Electrical

- Power requirements:
  - Voltage source: 18 to 30 V DC
  - Constant current diode: 2 to 10 mA, recommended 4 mA
- Electrical noise:
  - 2.0 Hz: 20 µg/√Hz
- Output impedance: < 100 Ω
- Bias output voltage: 12 V DC
- Grounding: Case isolated, internally shielded

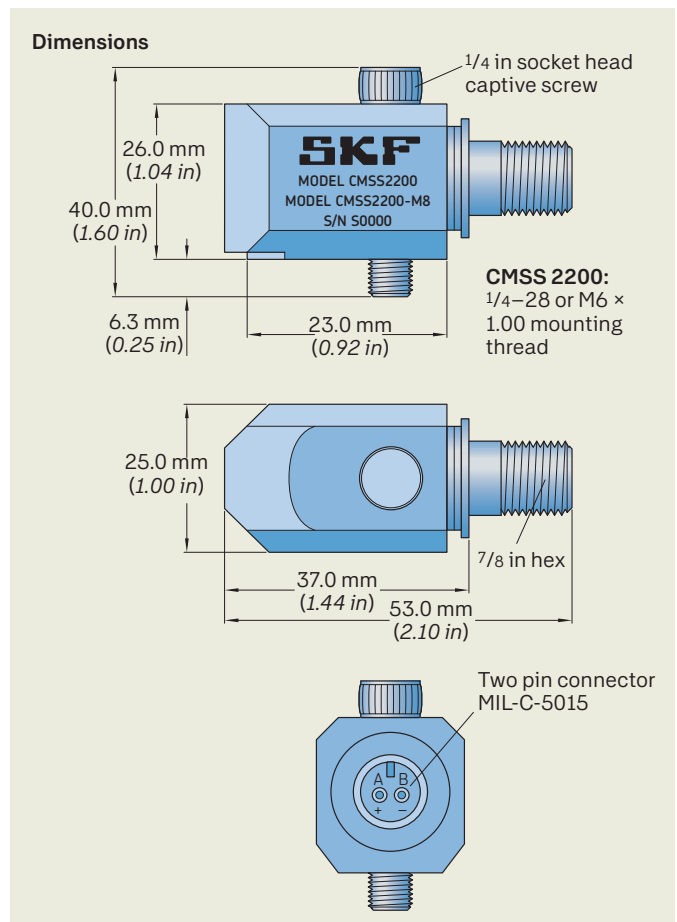

### Typical temperature response

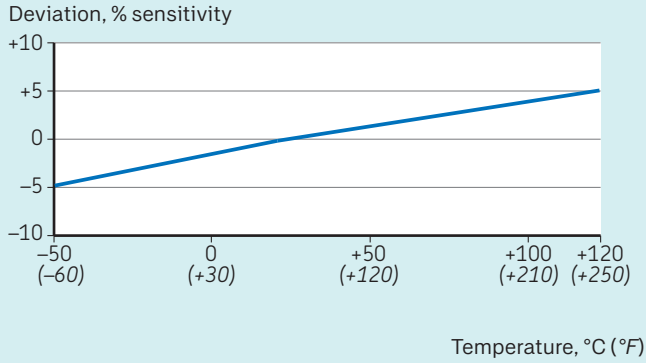

### Typical frequency response

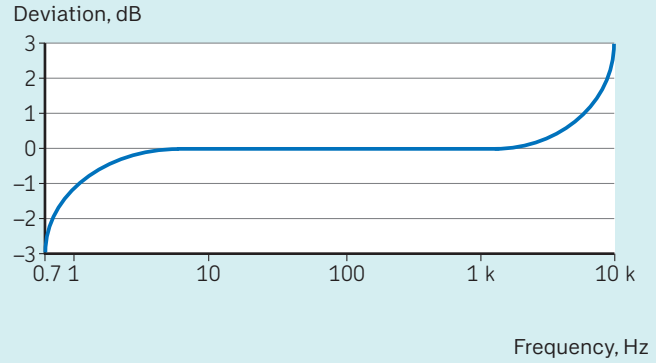

## Environmental

- Temperature range:  $-50$  to  $+120$  °C ( $-60$  to  $+250$  °F) operating temperature
- Vibration limit: 500 g peak
- Shock limit: 5 000 g
- Electromagnetic sensitivity, equivalent g, maximum: 30  $\mu$ g/gauss
- Sealing: Hermetic
- Base strain sensitivity: 0.002 g/ $\mu$ strain
- CE: According to the generic immunity standard for Industrial Environment EN 50082-2
  - Acceptance criteria: The generated “false equivalent g level” under the above test conditions should be less than 2 mg measured peak to peak

## Physical

- Dimensions: See drawing
- Weight: 135 g (4.8 oz.)
- Case material: 316L stainless steel
- Mounting:  $1/4$ -28 and M6  $\times$  1 captive socket head screw
- Mounting torque: 2.9 Nm (24 in lbs.)
- Connections:
  - Shell: Ground
  - Pin A: Power/Signal
  - Pin B: Common

### Ordering information

- CMSS 2200**
- Industrial accelerometer with side exit MIL-C-5015 two pin connector
  - $1/4$ -28 and M6  $\times$  1 captive socket head screw provided. Calibration sensitivity and nominal sensitivity is provided for each accelerometer package.

# CMSS 2100

## Industrial accelerometer, straight exit

The CMSS 2100 accelerometer is a good multi-purpose sensor. The sensor is commonly deployed in the following industries:

- Power Generation (Fossil, Nuclear, Hydro)
- Pulp and Paper
- Food and Beverage
- Automation
- Metals
- Water and Waste Water

## Features

- For use with all SKF portable data collection instruments
- Rugged, economical and all around general purpose sensor
- 100 mV/g sensitivity to optimize use in multiple applications
- Exceptional bias voltage (BV) stability at elevated temperatures
- Designed for exceptional low noise level over a wide temperature range
- Meets CE, EMC requirements
- Two mounting studs ( $1/4-28$  and  $M8 \times 1.25$ ) provided
- Corrosion resistant and hermetically sealed for installation in high humidity areas
- Reverse polarity wiring protection

## Recommended connector/cable assembly

- CMAC 5029 and CMAC 9100

## Specifications

Specifications conform to ISA-RP-37.2 (1-64) and are typical values referenced at 24 °C (75 °F), 24 V DC supply, 4 mA constant current and 100 Hz.

## Dynamic

- Sensitivity: 100 mV/g
- Sensitivity precision:  $\pm 5\%$  at 24 °C (75 °F)
- Acceleration range: 80 g peak
- Amplitude linearity:  $\leq 1\%$ , up to full scale
- Frequency range:
  - $\pm 5\%$ : 3.0 to 5 000 Hz
  - $\pm 10\%$ : 1.0 to 9 000 Hz
  - $\pm 3$  dB: 0.5 to 14 000 Hz
- Resonance frequency, mounted, nominal: 30 kHz
- Transverse sensitivity:  $\leq 5\%$  of axial
- Temperature response: See graph



## Electrical

- Power requirements:
  - Voltage source: 24 V DC nominal, 18 to 30 V DC
  - Constant current diode: 2 to 10 mA, recommended 4 mA
- Electrical noise:
  - 2.0 Hz: 20  $\mu\text{g}/\sqrt{\text{Hz}}$
- Output impedance:  $< 100 \Omega$
- Bias output voltage: 12 V DC
- Grounding: Case isolated, internally shielded

## Dimensions

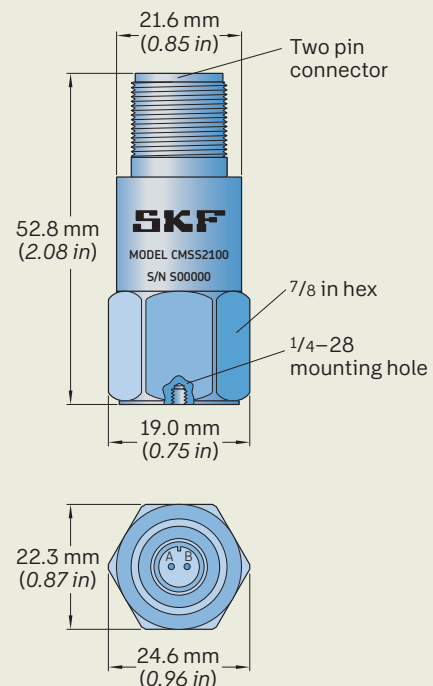



### Typical temperature response

Deviation, % sensitivity

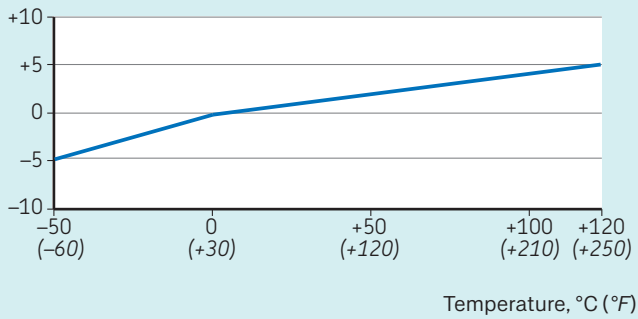

### Typical frequency response

Deviation, dB

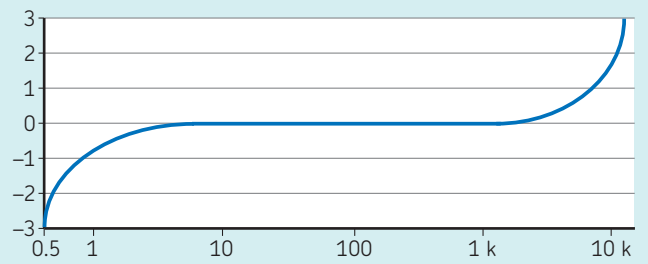

### Environmental

- Temperature range:  $-50$  to  $+120$  °C ( $-60$  to  $+250$  °F) operating temperature
- Vibration limit: 500 g peak
- Shock limit: 5 000 g peak
- Electromagnetic sensitivity, equivalent g, maximum: 70  $\mu\text{g/gauss}$
- Sealing: Hermetic
- Base strain sensitivity: 0.0002 g/ $\mu\text{strain}$
- CE: According to the generic immunity standard for Industrial Environment EN 50082-2
  - Acceptance criteria: The generated “false equivalent g level” under the above test conditions should be less than 2 mg measured peak to peak

### Physical

- Dimensions: See drawing
- Weight: 90 g (3.2 oz.)
- Case material: 316L stainless steel
- Mounting:
  - Internal  $1/4$ -28 thread
  - M8  $\times$  1.25 and  $1/4$ -28 to  $1/4$ -28 mounting studs provided
- Mounting torque: 2.9 Nm (24 in lbs.)
- Connections:
  - Pin A: Signal/Power
  - Pin B: Common

### Ordering information

**CMSS 2100** Industrial accelerometer, straight exit with MIL-C-5015 two pin connector.

- $1/4$ -28 and M8 mounting studs provided. Calibration sensitivity and nominal sensitivity is provided for each accelerometer package.

# CMSS 2111

## Small footprint accelerometer with integral cable

The CMSS 2111 is a small footprint accelerometer that includes an integrated 2 m (6.56 ft.) cable along with a magnetic mount. This accelerometer is capable of working to a depth of 5 m (16.4 ft.) (additional cable length required).

### Specifications

#### Dynamic

- Sensitivity ( $\pm 10\%$ ): 100 mVg
- Measurement range:  $\pm 50$  g
- Frequency range ( $\pm 3$  dB): 0,5 to 10 000 Hz
- Non-linearity:  $\pm 1\%$
- Resonance frequency: 22 kHz
- Transverse sensitivity:  $\leq 7\%$

#### Electrical

- Power supply:
  - Voltage source: 18 to 28 V DC
  - Constant current diode: 2 to 20 mA
- Electrical noise:
  - Broadband:
    - 1 Hz to 10 kHz: 350  $\mu$ g
  - Spectral:
    - 10 Hz: 8  $\mu$ g/ $\sqrt{\text{Hz}}$
    - 100 Hz: 5  $\mu$ g/ $\sqrt{\text{Hz}}$
    - 1 kHz: 4  $\mu$ g/ $\sqrt{\text{Hz}}$
- Output impedance:  $< 150 \Omega$
- Bias output voltage: 8 to 12 V DC
- Discharge time constant:  $\leq 0,3$  s
- Settling time (within 1% of bias):  $\leq 2,0$  s



#### Environmental

- Temperature range:  $-55$  to  $+120$  °C ( $-65$  to  $+250$  °F)
- Shock limit: 5 000 g peak
- Enclosure rating: IP 68

#### Physical

- Dimensions (hex  $\times$  height): 14  $\times$  64 mm (0.55  $\times$  2.52 in)
- Weight (with cable): 99 g (3.5 oz.)
- Cable length: 2 m (6.56 ft.)
- Mounting: Magnet
- Case material: Stainless steel
- Cable type: Polyurethane
- Sealing: Molded
- Sensing element design: Ceramic, shear
- Connections:
  - Molded integral cable (top)
  - Fischer type 103 six pin



#### Ordering information

- **CMSS 2111** Small footprint accelerometer with an integrated cable and a magnetic mount.

# CMSS 1500-K

## Industrial accelerometer, cable and magnet

The CMSS 1500 accelerometer is side entry for easy access and is a rugged designed multi-purpose sensor. The sensor is commonly deployed in a range of heavy industries, such as Pulp and Paper, Metals, Utilities, Mineral Process and Water & Wastewater.

This sensor is not suitable for high speed applications such as spindles.

CMSS 1500-K kit includes CMAC 9110, 2 m (6.56 ft.) coiled cable along with CMSS 908-MD magnetic mount



## Specifications

### Dynamic

- Sensitivity: 100 mVg
- Sensitivity precision:  $\pm 10\%$  at 22 °C (71.6 °F)
- Acceleration range:  $\pm 80$  g peak
- Amplitude linearity:  $\pm 1\%$
- Frequency range ( $\pm 3$  dB): 0,8 to 15 000 Hz
- Resonance frequency, mounted, normal: 21 kHz
- Transverse sensitivity:  $\leq 5\%$  of axial

### Electrical

- Power supply:
  - Voltage source: 18 to 30 V DC
  - Constant current diode: 0.5 to 8 mA
- EMC: EN 61326-1:2013
- Output impedance: 200  $\Omega$  max.
- Bias output voltage: 10 to 12 V DC
- Discharge time constant:  $\leq 0,3$  s
- Settling time (within 1% of bias):  $\leq 2,0$  s
- Grounding: Case isolated, internally shielded

### Environmental

- Temperature range:  $-55$  to  $+140$  °C ( $-65$  to  $+284$  °F)
- Shock limit: 5 000 g peak
- Enclosure rating: IP 67

### Physical

- Dimensions (length x width x height): 61 x 25 x 30 mm (2.4 x 0.99 x 1.18 in)
- Weight: 185 g (6.5 oz.)
- Case material: Stainless steel
- Mounting: 1/4–28 captive socket head screw
- Mounting torque: 8 Nm (70 in lbs.)
- Connections:
  - Pin 1: No connection
  - Pin 2: Power/Signal
  - Pin 3: No connection
  - Pin 4: Common
- Cable CMAC 9110 length: 2 m (6.56 ft.)
- Cable type: Polyurethane
- Cable connections:
  - Molded connectors
  - 4 pin M12 to BNC
- Mounting: CMSS 908-MD magnet

### Ordering information

- **CMSS 1500-K** industrial accelerometer with CMAC 9110 cable and CMSS 908-MD magnetic mount.
- 1/4–28 captive socket head screw provided. Calibration sensitivity and nominal sensitivity is provided for each accelerometer package.

# CMSS 908-MD

## Medium duty magnetic base

The CMSS 908-MD is a multi-purpose magnetic base designed for industrial vibration monitoring applications. The low profile magnet has a 1/4-28 mounting hole to allow compatibility with SKF accelerometers and provides a solid mechanical connection to the machine.



## Specifications

- Diameter: 35 mm (1.38 in)
- Height: 18 ± 1 mm (0.75 in)
- Mounting hole: 1/4-28
- Pull strength: 23 kg (50 lbs.)

## Accelerometer compatibility

The CMSS 908-MD medium duty magnetic base is compatible with the following accelerometers:

- CMSS 2200: General purpose, low profile, side exit industrial accelerometer
- CMSS 2100: General purpose, top exit industrial accelerometer

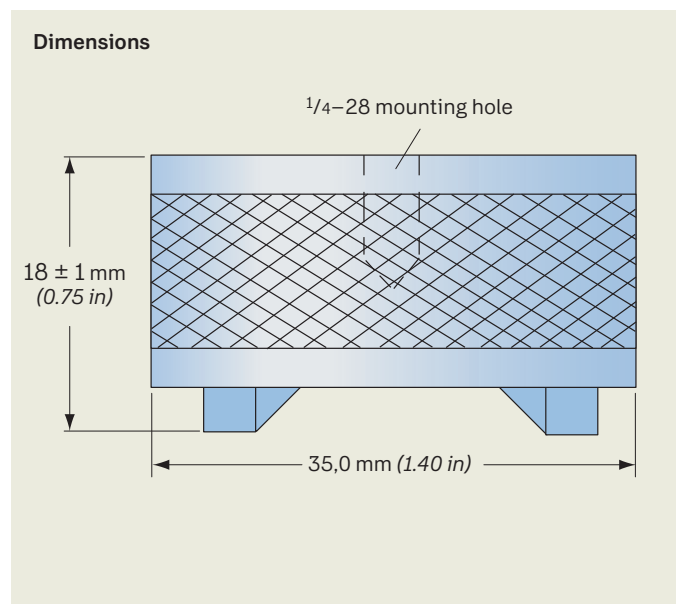

## Ordering information

- CMSS 908-MD Medium duty magnetic base.

## SKF Quick Connect mounting

### Model number

### Description

CMSS 910QDB1  
CMSS 910QDP1  
CMSS 910QDP2

Quick connect/disconnect sensor mounting pads

Mounting pads allow vibration technicians using such instruments as the SKF Microlog dBX on walkaround routes to quickly mount vibration sensors in less than one turn. This quick mount design results in a decrease in mounting time as compared to the older style threaded stud mounting pads.

#### Key benefits:

- Decreases sensor mounting time by 90%
- Eliminates wrist fatigue from repetitive twisting
- Combines ease and speed of a magnet mount with the accuracy and repeatability of a permanent mount
- Ensures the repeatable, reliable vibration data of a permanently mounted sensor
- Prevents cable twisting
- Upgrades existing installations

#### Features:

- Constructed of corrosion resistant 316 stainless steel
- Convenient cement mounting capability
- Accepts all  $1/4-28$  compatible vibration sensors, including SKF's low profile models
- Compatible with existing  $1/4-28$  stud mount installations
- Can be easily removed to upgrade to permanent mount allowing the sensor to be directly attached to the same measuring point

### CMSS 910QDB1

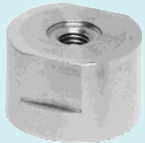

Quick connect adapter sensor base

- The CMSS 910QDB1 attaches easily to  $1/4-28$  compatible sensors
- In walkaround data collection, the sensor can be attached in less than one turn to any of the quick connect/disconnect mounting pads
- The CMSS 910QDB1 can remain on the sensor or be removed and reattached to other SKF vibration sensors

### CMSS 910QDP1

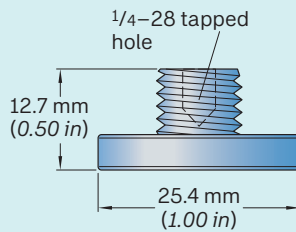

Quick connect, threaded stud mounting pad

- The CMSS 910QDP1 is stud mounted to the measuring point or attached to an existing  $1/4-28$  stud
- Easy conversion to permanently mounted sensors
- Once the CMSS 910QDP1 is mounted, conversion to permanently mounted sensors is quick and easy
- By simply removing the pad and attaching an SKF vibration sensor to the existing  $1/4-28$  stud, sensor location and vibration data history remains reliable

### CMSS 910QDP2

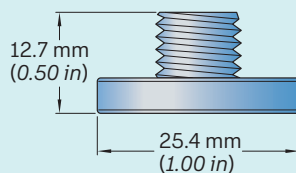

Quick connect, cement mounting pad

- The CMSS 910QDP2 is epoxied to the measuring point
- Removable for upgrading to permanently mounted sensors
- When upgrading to permanently mounted sensors, the cement pad can easily be removed to allow a stud mounted sensor to be installed in the location

**Recommended with Loctite 454 adhesive gel (not included).**

# Cables

## Cable recommendations

The following tables show which cables are recommended for the accelerometers and hardware found in this catalog.

Cables recommended for accelerometers		Cable model number				
Accelerometer model number	Accelerometer description	CMAC 9110	CMAC 5209	CMAC 9100	CMAC 5036	CMAC 5037
CMSS 1500	General purpose, low profile, side exit industrial accelerometer	●				
CMSS 2100	General purpose, top exit industrial accelerometer		●	●	●	●
CMSS 2200	General purpose, low profile, side exit industrial accelerometer		●	●	●	●

Cables recommended for hardware, etc.		Cable model number				
Hardware model number	Product description	CMAC 5023	CMAC 5044	CMAC 5078	CMAC 5088	CMAC 5214
CMAC 5030K	Laser tachometer kit		●			
CMAC 5059	Modal analysis hammer kit	●			●	●

### Important

SKF Microlog dBX ALL CH and TRIG/PWR connectors use a locking mechanism for secure connections. To disconnect Fischer cables from the SKF Microlog dBX connectors, pull up on the **lower** portion of the connector, as illustrated below.

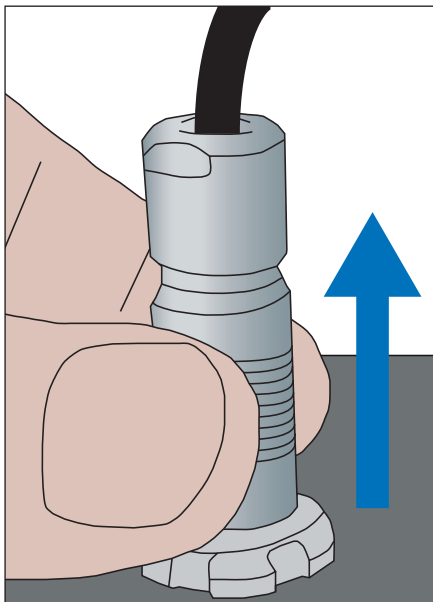

Correct way to disconnect cables

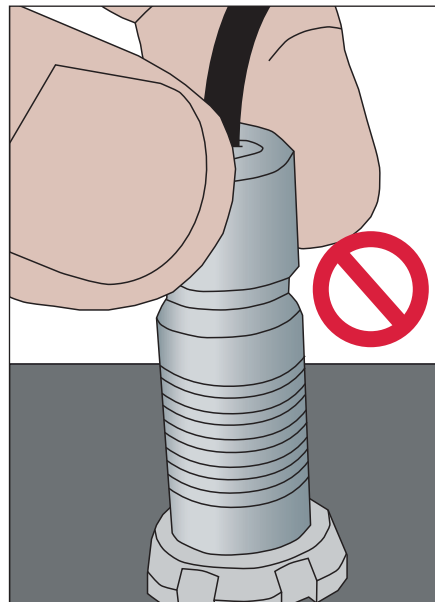

Wrong way to disconnect cables

## CMAC 5079

### Splitter, straight cable

The CMAC 5079 cable is used for splitting CH ALL on the SKF Microlog dBX. Lead A gives channel 1 and lead B gives channel 4.

### Specifications

- Connectors: Two Fischer type 103 six pin female sockets to one Fischer type 103 six pin male
- Length: 41 cm (1.35 ft.) straight



#### Ordering information

- **CMAC 5079** Splitter, straight cable.

## CMAC 9020

### Splitter, straight cable

The CMAC 9020 cable is used for splitting CH ALL on the Microlog dBX. Lead A gives channel 1 and lead B gives channel 2.

### Specifications

- Connectors: two Fischer type 103 six pin female sockets to one Fischer type 103 six pin male
- Length: 41 cm (1.35 ft.) straight



#### Ordering information

- **CMAC 9020** Splitter, straight cable.

## CMAC 5209

### Accelerometer coiled cable, 2 m (6.56 ft.)

The CMAC 5209 coiled cable connects to CH ALL input connector at one end and to an accelerometer at the other end. The accelerometer connection is a two pin MIL connector.

#### Specifications

- Connectors: Fischer type 103 six pin to two pin MIL
- Length: 2 m (6.56 ft.) coiled



## CMAC 5211

### BNC tachometer straight cable

The CMAC 5211 cable connects to the power connector at one end (using the power connector's tachometer input pin) and to any male BNC connector on the other end. It can be used with any tachometer signal source that does not require the SKF Microlog dBX to power it.

#### Specifications

- Connectors: Fischer type 103 seven pin trigger I/P to BNC
- Length: 1 m (3.28 ft.) straight



#### Ordering information

- **CMAC 5209** Accelerometer, coiled cable.

#### Ordering information

- **CMAC 5211** BNC tachometer straight cable.



## CMAC 5214

### Laser tachometer kit straight cable, 2 m (6.56 ft.) for CMAC 5030K

The CMAC 5214 laser tachometer cable connects the tachometer to the SKF Microlog dBX.

The CMAC 5214 cable, which is also included in the CMAC 5030K laser tachometer kit, allows the user to place the tachometer on a stationary surface up to 2 m (6.56 ft.) away from the SKF Microlog dBX.

#### Specifications

- Connectors: Fischer type 103 seven pin to four pin socket
- Length: 2 m (6.56 ft.) straight



#### Ordering information

- **CMAC 5214** Laser tachometer kit straight cable, 2 m (6.56 ft.).

## CMAC 5036

### Signal input straight extension cable, 5 m (16.4 ft.)

The CMAC 5036 cable, which is used for CH ALL signal input, is a straight extension cable that is 5 m (16.4 ft.) long. This cable can be used with single channel and triax sensors.

#### Specifications

- Connectors: Fischer type 103 six pin female to Fischer type 103 six pin male
- Length: 5 m (16.4 ft.) straight



#### Ordering information

- **CMAC 5036** signal input straight extension cable, 5 m (16.4 ft.).

## CMAC 5037

### Signal input straight extension cable, 10 m (32.8 ft.)

The CMAC 5037 cable, which is used for CH ALL signal input, is a straight extension cable that is 10 m (32.8 ft.) long. This cable can be used with single channel and triax sensors.

#### Specifications

- Connectors: Fischer type 103 six pin female to Fischer type 103 six pin male
- Length: 10 m (32.8 ft.) straight



#### Ordering information

- **CMAC 5037** signal input straight extension cable, 10 m (32.8 ft.).

## CMAC 5044

### Tachometer straight extension cable, 10 m (32.8 ft.)

The CMAC 5044 straight extension cable is for use with the CMAC 5030K laser tachometer kit. This cable is 10 m (32.8 ft.) long and can be used in conjunction with the CMAC 5211 cable.

#### Specifications

- Connectors: Fischer type 103 seven pin female to Fischer type 103 seven pin male
- Length: 10 m (32.8 ft.) straight



#### Ordering information

- **CMAC 5044** Tachometer straight extension cable, 10 m (32.8 ft.).

## CMAC 3715

### Cable converter, two pin MIL to BNC

The CMAC 3715 adapter, when combined with the CMAC 5209 accelerometer cable, allows the SKF Microlog dBX to connect to any male BNC connector. This is useful for reading buffered outputs from protection systems, switch boxes or process signal sources.

The adapter does not block DC signals, so the user must be careful to avoid applying power to a buffered signal output.

### Specifications

- Connectors: Two pin MIL to BNC
- Length: 8,5 cm (3.35 in)



## CMAC 5023

### Signal input straight cable

The CMAC 5023 cable connects to the SKF Microlog dBX CH ALL signal input connector at one end and to any male BNC connector at the other end. This lightweight cable can also be used in the CMAC 5056 and CMAC 5059 modal analysis hammer kits.

**Note:** Refer to CMAC 5088 for a heavy duty version of this cable.

### Specifications

- Connectors: Fischer type 103 six pin CH1 I/P to BNC
- Length: 1 m (3 ft.) straight



#### Ordering information

- **CMAC 3715** Cable converter, two pin MIL to BNC.

#### Ordering information

- **CMAC 5023** Signal input straight cable.

## CMAC 5032

### Power/Trigger splitter straight cable

The CMAC 5032 cable allows the connection of the tachometer, and instrument power (via the CMAC 9002 cable) simultaneously.

### Specifications

- Connectors: One Fischer type 103 seven pin plug to two Fischer type 103 seven pin sockets
- Length: 30 cm (11.8 in)
- Cable: Eight-core 24 AWG screened cable



## CMAC 5088

### Signal input straight cable (BNC connector)

The CMAC 5088 cable is a heavy duty version of the CMAC 5023 cable. The CMAC 5088 cable connects to the SKF Microlog dBX CH ALL signal input connector at one end and to any male BNC connector at the other end.

**Note:** Refer to CMAC 5023 for a lightweight version of this cable.

### Specifications

- Connectors: Fischer type 103 six pin CH1 I/P to BNC
- Length: 2 m (6.56 ft.) straight



#### Ordering information

- **CMAC 5032** Power/Trigger splitter straight cable.

#### Ordering information

- **CMAC 5088** Signal input straight cable (BNC connector).

## CMAC 5093

### Signal input coiled cable (BNC connector)

The CMAC 5093 cable has a BNC connector on one end to connect to CH ALL connector on the SKF Microlog dBX.

### Specifications

- Connectors: Fischer type 103 six pin to BNC
- Length: 51 cm (20 in) coiled



#### Ordering information

- **CMAC 5093** Signal input coiled cable (BNC connector).

## CMAC 9100

### Accelerometer coiled BNC cable

The CMAC 9100 coiled cable is used to connect to either CH1, CH2, CH3 or CH4 input connector to an accelerometer. It has a BNC connector at one end for SKF Microlog dBX and the other end connects to accelerometer.

### Specifications

- Connectors: BNC connector to two pin MIL
- Length: 2 m (6.56 ft.) coiled



#### Ordering information

- **CMAC 9100** Accelerometer coiled BNC cable.

## CMAC 9110

### Accelerometer (M12) coiled BNC cable

The CMAC 9110 coiled cable is used to connect to either CH1, CH2, CH3 or CH4 input connector to a M12 connector accelerometer. It has a BNC connector at one end for SKF Microlog dBX and the other end connects to M12 accelerometer.

### Specifications

- Connectors: BNC connector to M12 connector
- Length: 2 m (6.56 ft.) coiled



#### Ordering information

- **CMAC 9110** Accelerometer M12 connector, coiled BNC cable.

# Hardware

## CMAC 5030K

### Laser tachometer kit

The CMAC 5030K laser tachometer kit contains a small tachometer for easy mounting. Along with the tachometer, this kit includes a bracket for mounting the tachometer directly to the SKF Microlog dBX using the camera mount located on the bottom of the SKF Microlog dBX. The kit also includes a two-meter cable to connect the tachometer to the SKF Microlog dBX and a small tripod for a stationary mounting of the tachometer during the measurement. The key features of this laser tachometer kit include:

- Operating frequency up to 250 000 r/min
- Long optical range, up to 2 m (6.56 ft.)
- Wide angle of operation, up to 80°
- On target indicator standard
- Protection rating: IP 67

### Specifications

- Material: Stainless steel body
- Color: Silver
- Laser type: Class 2
- Optical range: 100 to 2 000 mm (0.33 to 6.56 ft.)
- Power: 1 mW maximum
- Current consumption: 45 mA maximum
- Cable: Fischer seven pin type 103 to four pin socket, 2 m (6.56 ft.)
- Wavelength: 635 mm (25 in)
- Angle of incidence:  $\pm 80^\circ$
- Speed range: 0,1 to 250 000 r/min
- Power input: 5 V DC or 8–24 V DC versions at 30 mA typically
- Operating temperature:  $-10$  to  $+40$  °C (15 to 105 °F)
- IP rating: IP 67
- Housing types: M20 threaded or plain body plus fixing slots
- Connections: Integral connector
- Dimensions: 70 × 20 mm (2.76 × 0.79 in)
- Weight: 70 g (2.5 oz.)

### Kit contents

- Compact laser tachometer
- Mounting bracket
- Reflective tape strips
- Mini mounting tripod
- CMAC 5214: Tachometer interface cable, 2 m (6.56 ft.)



Compact laser tachometer



Mounting bracket



Reflective tape strips



Mini mounting tripod



CMAC 5214 tachometer interface cable

### Ordering information

- **CMAC 5030K** Laser tachometer kit. Each kit includes a compact laser tachometer, mounting bracket, cable and mini tripod.

# CMAC 5056

## Modal analysis hammer kit

### Features

- Frequency range up to 8 kHz
- Peak force 2 200 N (500 lb. ft.)
- Output 2,25 mV/N (10 mV/lb. ft.)
- Mass extender to provide additional force

These calibrated modal hammer kits may be used for impulse testing of the dynamic behavior of mechanical structures by striking the object with the hammer and measuring the resulting response with the accelerometer. The hammer imparts a constant force over a broad frequency range, which depends on the type of tip used.

The hammer has an integral, constant current quartz force sensor mounted on the striking end of the hammer head. The sensor converts the impact force into electrical signal for display and analysis.

It is designed with rigid quartz crystals and a built-in, microelectronic, unity gain amplifier. Due to the laser-welded construction of the sensor element, operation is reliable in adverse environments.

The striking end of the hammer has a threaded hole for installation of a variety of impact tips that are included in the kit. The tip transfers the impact force to the sensor and protects the sensor face from damage. Tips of different stiffness allow the variation of the pulse width and correspondingly the frequency content of the force.

Modal analysis and modeling is also available by fixing the accelerometer at one location, impacting the structure at one point and then moving the accelerometer to other points of interest:

- Apparent mass/Accelerance
- Impedance/Mobility
- Stiffness/Compliance



### Specifications

#### CMAC 5056 Accelerometer (353B04)

##### Dynamic

- Sensitivity ( $\pm 5\%$ ): 1,02 mV/(m/s<sup>2</sup>) (10 mVg)
- Measurement range:  $\pm 4\,905$  m/s<sup>2</sup> peak ( $\pm 500$  g peak)
- Frequency range:
  - $\pm 5\%$ : 1 to 7 000 Hz
  - $\pm 10\%$ : 0,7 to 11 000 Hz
  - $\pm 3$  dB: 0,35 to 20 000 Hz
- Resonant frequency:  $\geq 38$  kHz
- Broadband resolution (1 to 10 000 Hz): 0,03 m/s<sup>2</sup> RMS (0,003 g RMS)
- Non-linearity:  $\leq 1\%$
- Transverse sensitivity:  $\leq 5\%$

##### Electrical

- Excitation voltage: 18 to 30 V DC
- Constant current excitation: 2 to 20 mA
- Output impedance:  $\leq 100 \Omega$
- Output bias voltage: 8 to 12 V DC
- Discharge time constant: 0,5 to 2,0 s
- Settling time (within 10% of bias):  $< 5$  s
- Spectral noise:
  - 1 Hz: 3 200  $\mu\text{g}/\sqrt{\text{Hz}}$
  - 10 Hz: 700  $\mu\text{g}/\sqrt{\text{Hz}}$
  - 100 Hz: 180  $\mu\text{g}/\sqrt{\text{Hz}}$
  - 1 kHz: 64  $\mu\text{g}/\sqrt{\text{Hz}}$

**Environmental**

- Overload limit (shock):  $\pm 98\ 100\ \text{m/s}^2\ \text{pk}$  ( $\pm 10\ 000\ \text{g}\ \text{pk}$ )
- Temperature range (operating):  $-55\ \text{to}\ +120\ ^\circ\text{C}$  ( $-65\ \text{to}\ +250\ ^\circ\text{F}$ )
- Base strain sensitivity:  $\leq 0,0005\ \text{g}/\mu\ \text{strain}$

**Physical**

- Size (hex x height):  $12,7 \times 29,0\ \text{mm}$  ( $0.50 \times 1.14\ \text{in}$ )
- Weight:  $10,5\ \text{g}$  ( $0.38\ \text{oz.}$ )
- Sensing element: Quartz
- Sensing geometry: Shear
- Housing material: Titanium
- Sealing: Welded hermetic
- Electrical connector: 10–32 coaxial jack
- Electrical connection position: Top
- Mounting thread: 10–32 female

**Kit contents**

The CMAC 5056 hammer kit can be used on structures with a mass of 210 g (7.6 oz.) and above.

The accelerometers that are included with the CMAC 5056 kit are constant current, low impedance, voltage-mode sensors. Microelectronic, built-in amplifiers standardize sensitivities within a few percent of nominal value.

**CMAC 5056 kit include**

- Calibrated hammer
- Cable – BNC to Fischer six pin (for a sturdier cable CMAC 5023, may be used)
- Red hammer tips (two)
- White hammer tip
- Black hammer tips (two)
- Steel tip
- Blue tip covers (two)
- Petro wax
- Screws threaded on both ends (two)
- Hammer extender
- Carrying case
- 353B04 Accelerometer
- Magnetic accelerometer base
- Cable – Fischer six pin to Microdot



*Calibrated hammer*



*353B04 accelerometer*



*Hammer extender*



*Magnetic accelerometer base*



*Red hammer tip*



*White hammer tip*



*Black hammer tip*



*Steel tip*



*Blue tip cover*



*Petro wax*



*Screw (threaded on both sides)*





*Microdot to Fisher cable*



*BNC to Fischer cable*



*Carrying case (contents may vary)*

#### Ordering information

- **CMAC 5056** Modal hammer kit – for use on structures with a mass of 210 g (7.6 oz.) and above. Includes hammer, accelerometer, magnetic mount, adhesive mounting base with Petro wax, two cables, carrying case, certificate of conformance and calibration certificate.

# CMAC 5059

## Modal analysis hammer kit

This calibrated modal hammer kit may be used for impulse testing of the dynamic behavior of mechanical structures by striking the object with the hammer and measuring the resulting response with an accelerometer. The hammer imparts a constant force over a broad frequency range, which depends on the type of tip used.

The hammer has an integral, constant current quartz force sensor mounted on the striking end of the hammer head. The sensor converts the impact force into electrical signal for display and analysis.

It is designed with rigid quartz crystals and a built-in, microelectronic, unity gain amplifier. Due to the laser-welded construction of the sensor element, operation is reliable in adverse environments.

The striking end of the hammer has a threaded hole for installation of a variety of impact tips that are included in the kit. The tip transfers the impact force to the sensor and protects the sensor face from damage. Tips of different stiffness allow the variation of the pulse width and correspondingly the frequency content of the force.

Modal analysis and modeling is also available by fixing the accelerometer at one location, impacting the structure at one point and then moving the accelerometer to other points of interest. When used with the FRF module, the following modal parameters can be calculated and displayed:

- Apparent mass/Accelerance
- Impedance/Mobility
- Stiffness/Compliance

## Specifications

### Dynamic

- Sensitivity ( $\pm 15\%$ ): 0,23 mV/N (1 mV/lbf)
- Measurement range:  $\pm 22\ 240$  N peak ( $\pm 5\ 000$  lbf peak)
- Resonant frequency:  $\geq 12$  kHz
- Non-linearity:  $\leq 1\%$



### Electrical

- Excitation voltage: 20 to 30 V DC
- Constant current excitation: 2 to 20 mA
- Output impedance:  $< 100\ \Omega$
- Output bias voltage: 8 to 14 V DC
- Discharge time constant:  $\geq 1\ 400$  s

### Physical

- Sensing element: Quartz
- Sealing: Hermetic
- Hammer mass: 1,1 kg (2.4 lb.)
- Head diameter: 5,1 cm (2.0 in)
- Tip diameter: 5,1 cm (2.0 in)
- Hammer length: 37 cm (14.5 in)
- Electrical connection position: Bottom of handle
- Electrical connector: BNC jack

## Kit contents

- Calibrated hammer
- Super soft plastic, gray tip
- Medium plastic, red tip
- Hard plastic, black tip
- CMAC 5088: Cable – BNC to Fischer six pin
- Carrying case



*Hammer*



*Gray hammer tip*



*Red hammer tip*



*Black hammer tip*



*Carrying case*



*CMAC 5088 cable*

#### Ordering information

- **CMAC 5059** Modal hammer kit. Includes hammer, three tips, cable, carrying case, certificate of conformance and calibration certificate.

# Accessories

## CMAC 9005

### Battery

Lithium-Ion rechargeable battery pack provides customers with up to eight hours of continuous data collection. The battery can be charged in the instrument.

**Note:** SKF Microlog dBX takes up to two CMAC 9005 batteries.



### Specifications

#### Electrical

- Nominal voltage: 14,4 V
- Nominal capacity: 2270 mAh, 32,7 Wh
- Operating time, two batteries installed:
  - up to 8 hours in data collection
- Charge time:
  - 6 hours (in suspend mode)

#### Environmental

- Temperature range:
  - Charging: +10 to +45 °C (50 to 115 °F)
  - Operating: –10 to +50 °C (15 to 122 °F)
  - Storage (1 Year): –20 to +20 °C (–5 to +70 °F)

#### Physical

- Dimensions: 111 × 13 × 71 mm (4.4 × 0.5 × 2.8 in)
- Weight: 200 g (7 oz.)

#### Approvals

- Transportation UN Directive ST / SG / AC.10 / 11 / Rev.5, sub-section 38.3
- Equivalent Lithium content: <2 g (0.0705 oz.)

#### Ordering information

- **CMAC 9005** SKF Microlog dBX battery.

## CMAC 9001

### Universal power supply

The CMAC 9001 universal power supply delivers power to the SKF Microlog dBX while charging the battery when inside the instrument. Adapter cable (CMAC 9002) is used to connect to SKF Microlog dBX. Since this universal power supply can support 100 to 240 V input, it also comes with USA, UK, AUS and EURO adapter plugs.



## CMAC 9002

### Power supply adapter cable

The CMAC 9002 adapter cable is used to connect the universal power supply (CMAC 9001) in-line DC jack socket to the Fischer socket on the SKF Microlog dBX.

### Specifications

- Connector 2.1 mm (0.083 in) in-line DC jack socket to Fischer SE103xxxx-130 plug
- Length: 30 cm (11.8 in)



#### Ordering information

- **CMAC 9001** Universal power supply, includes four plug adapters.

#### Ordering information

- **CMAC 9002** Power supply adapter cable.

## CMAC 9017

### Neck strap

The CMAC 9017 neck strap is adjustable and features a steel plate that has been designed to hold a few transducers (if fitted with a magnetic mount).



## CMAC 9016

### Hand strap

The hand strap is provided in all kits and is designed for easier and safer operation of the instrument. It enables the operator to hold onto the unit with one hand and still press the keypad. The hand strap fastens directly to the instrument.



#### Ordering information

- CMAC 9017 Neck strap.

#### Ordering information

- CMAC 9016 Hand strap.

# CMAC 9010

## USB communications cable

The CMAC 9010 is a USB type A to USB type A cable. The cable is used for USB communications between SKF Microlog dBX and host computer. Either end can be connected to the USB socket on the SKF Microlog dBX device.

## Specifications

- Connectors: USB type A to USB type A
- Length: 2 m (6.56 ft.) straight"



### Ordering information

- **CMAC 9010** USB communications cable.

[skf.com/microlog-dbx](https://skf.com/microlog-dbx)

® SKF, MICROLOG, and MULTILOG are registered trademarks of AB SKF (publ).  
Bluetooth is a registered trademark of Bluetooth SIG, Inc.  
ICP is a registered trademark of PCB Group, Inc.  
Intel and Intel XScale are registered trademarks of Intel Corporation in the United States and other countries.  
Marvell is a registered trademark of Marvell or its affiliates.  
Microsoft, Windows, ActiveSync, Excel, PowerPoint, SQL Server, Windows Server and Windows Vista are either registered trademarks or trademarks of Microsoft Corporation in the United States and / or other countries.  
Oracle is a registered trademark of Oracle Corporation.  
All other trademarks are the property of their respective owners.

© SKF Group 2024. All rights reserved. Please note that this publication may not be copied or distributed, in whole or in part, unless prior written permission is granted.

Every care has been taken to ensure the accuracy of the information contained in this publication, but no liability can be accepted for any loss or damage whether direct, indirect or consequential arising out of the use of the information contained herein.

**PUB CM/P1 19569/2 EN** · October 2024

This publication is superseded by PUBCM/P1 11643\_9 EN